

Sensor Networks Overview

Sensors networks are in widespread use in factories, industrial complexes, commercial and residential buildings, agricultural settings, and urban areas, serving to improve manufacturing efficiency, safety, reliability, automation, and security. These networks perform a variety of useful functions including factory automation, measurement, and control; control of lighting, heating, and cooling in residential and commercial buildings; structural health monitoring of bridges, commercial buildings, aircraft, and machinery; tire pressure monitoring systems (TPMS); tank level monitoring; and patient monitoring in hospitals and nursing homes.

To date almost all sensor networks use wired connections for data communications and power. The cost of installing a sensor network using copper wire, conduit, along with the support infrastructure has become extremely cost-prohibitive. There are new emerging solutions using various wireless protocols such as Wi-Fi 802.11 a/b/g/n or ZigBee to connect sensor devices to the network and eliminate the data communications wiring. However, the wireless sensors still need to be powered. Using batteries such as AA cells has been used as a solution. But these batteries wear out and changing them out is often an expensive proposition. OnWorld Research has estimated that this battery change-out cost will approach \$1 Billion in 2013. What is needed is a solution that harvests the ambient energy around the wireless sensor device.

Ubiquitous Sensor Networks

Ubiquitous Sensor Networks (USNs) is the term that is used for wireless sensor and control networks that use batteries or Energy Harvesting techniques to power the device. With the availability of low cost integrated circuits to perform the sensing, signal processing, communication, and data collection functions, coupled with the versatility that wireless networks afford, we can move away from fixed, hard-wired network installations in both new construction as well as retrofits of existing installations.

Zero Power Wireless Sensors

One drawback to moving toward a wireless network installation has been the poor reliability and limited useful life of batteries needed to supply the energy to the sensor, radio, processor, and other electronic elements of the system. This limitation has to some extent curtailed the proliferation of wireless networks. The batteries can be eliminated through the use of Energy Harvesting techniques which use an energy conversion transducer tied to an integrated rechargeable power storage device. This mini "power plant" lasts the life of the wireless sensor.

A Zero Power Wireless Sensor as shown in Figure 1 typically consists of five basic elements:

- 1) The **sensor** itself, to detect and quantify any number of environmental parameters such as motion, proximity, temperature, pressure, pH, light, strain, vibration, and many others.
- 2) An **energy harvesting transducer** that converts some form of ambient energy to electricity.
- 3) A **power module** to collect, store and deliver electrical energy to the electronic or electro-mechanical devices resident at the sensor node.
- 4) A **microcontroller** or variant thereof to receive the signal from the sensor, convert it into a useful form for analysis, and communicate with the radio link.
- 5) A **radio link** at the sensor node to transmit the information from the processor on a continuous, periodic, or event-driven basis to a host receiver and data collection point.

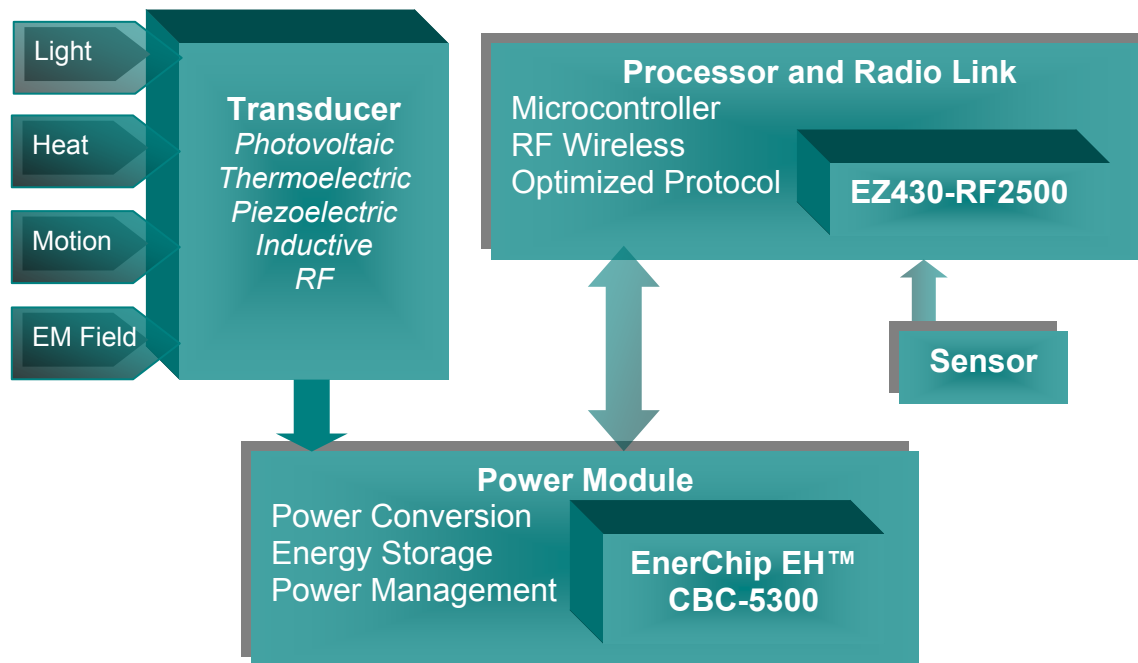

Figure 1: Zero Power Wireless Sensor Diagram

Sensors

Sensors of all types can be deployed in wireless networks, whether to improve the quality of life as in the case of occupancy sensors in an assisted living facility; a light level sensor to reduce energy consumption in a commercial building; a proximity sensor used to maximize the flow of product in a manufacturing line; or a fluid sensor to monitor the quantity of liquid in a tank of oil. These are but a few examples of the

thousands of applications where wireless sensor networks are being used today. The response to the inflow of information can be immediate or delayed and can take many forms. Reactions and responses are specific to the environment in which the network is being used. For example, it might be necessary to send a signal to an actuator to open or close a valve based on the input from a pressure or temperature sensor.

Energy Harvesting Transducers

Traditional power sources for wireless sensors have typically been a primary (i.e., non-rechargeable) battery such as AA or AAA alkaline cells, lithium thionyl chloride, lithium coin cells, or a host of other chemistries. Each type of battery has specifications unique to the chemistry and cell construction. Some chemistries perform well at higher temperature; some offer high energy density, while others are designed for prolonged periods of steady state current drain. Regardless of cell design, construction, and chemistry, all batteries have inherent limitations with respect to operating life, ability to deliver high pulse currents, and so on. Moreover, by their very nature, primary cells are not rechargeable and therefore will eventually be depleted of charge.

While designers go to great lengths to minimize quiescent and periodic power consumption, as well as reducing the transmitter duty cycle as much as the network constraints permit, traditional batteries have a finite charge capacity and will eventually be exhausted due to power consumption from the load (in addition to the self-discharge of the cell itself). Depending on the operating environment and conditions, the battery being used to deliver power to a wireless sensor node might have an operational life of anywhere from a few months to several years. In addition to bearing the expense of battery replacement, system reliability is always at stake and is something the system manager must be aware of. The implications of a wireless node failing without warning vary according to function the node is serving.

But there is another way of providing the power source – harvesting the ambient energy surrounding the sensor device. Energy Harvesting delivers the necessary power and energy to operate the sensor node and, further, does not require battery maintenance during the operational life of the sensor node. In effect, Energy Harvesting enables perpetual sensors.

Energy Harvesting transducers are a source of power that is regularly or constantly available. This power source could come in the form of a temperature differential, a vibrational source such as an AC motor, a radiating or propagating electromagnetic wave, or a light source, as examples. Any of these power sources can be converted to useful electrical energy using transducers designed to convert one of those forms of power to electrical power.

The following transducers are the most common as shown in Figure 2:

- Photovoltaic: also known as solar - converts light to electrical power
- ElectroStatic or ElectroMagnetic – converts vibrations
- Thermoelectric: converts a temperature differential to electrical power
- Piezoelectric: converts a mechanical movement to electrical power
- RF and Inductive: converts magnetic power to electrical power

Energy Source	Design Challenge	Estimated Power (in 1 cm³ or 1 cm²)
Light	Conform to small surface area Wide input voltage range	10μW-15mW (Outdoors: 0.15mW-15mW) (Indoors: <10μW)
Vibrations	Variability of vibration	1μW-200μW (Electrostatic: 50μW-100μW) (Electromagnetic: <1μW)
Thermal	Small thermal gradients	15μW (10°C gradient)
Piezoelectric	Capturing pressure or motion	~ 200μW
RF & Inductive	Coupling & rectification	Varlous

Source: EE Times

Figure 2: Zero Power Wireless Sensor Diagram

The efficiency and power output of each transducer varies according to transducer design, construction, material, operating temperature, as well as the input power available and the impedance matching at the transducer output.

Power Module

Zero Power Wireless Sensors require a power module to condition the transducer output power, store power and deliver power to the rest of the wireless sensor. In most environments, any of transducers producing power cannot be relied on under all circumstances to continuously supply power to the load. While each transducer delivers power at some amplitude and with some regularity, they do not store energy. Consequently, when that source of power is not present, there would be no power to supply the load in the absence of an energy storage device. Moreover, the transducers typically do not deliver power at the proper voltage to operate the electronic system; therefore, conditioning of transducer power is essential to making the power useful in operating the sensor, processor, and transmitter. In particular, without an energy storage device, it would be difficult or impossible to deliver the pulse current necessary to drive the wireless transmitter.

Traditional rechargeable energy storage devices such as supercaps and coin cell batteries have severe limitations with respect to charge/discharge cycle life, self-discharge, and charge current and voltage requirements.

A new energy storage device is now available that meets the needs of Energy Harvesting. The EnerChip™ from Cymbet is a solid state thin film battery featuring a high charge/discharge cycle life, low self-discharge, fast recharge, and simple voltage-controlled charging. These characteristics make it an ideal energy storage cell for wireless sensor nodes utilizing energy harvesting, thus enabling perpetual sensing.

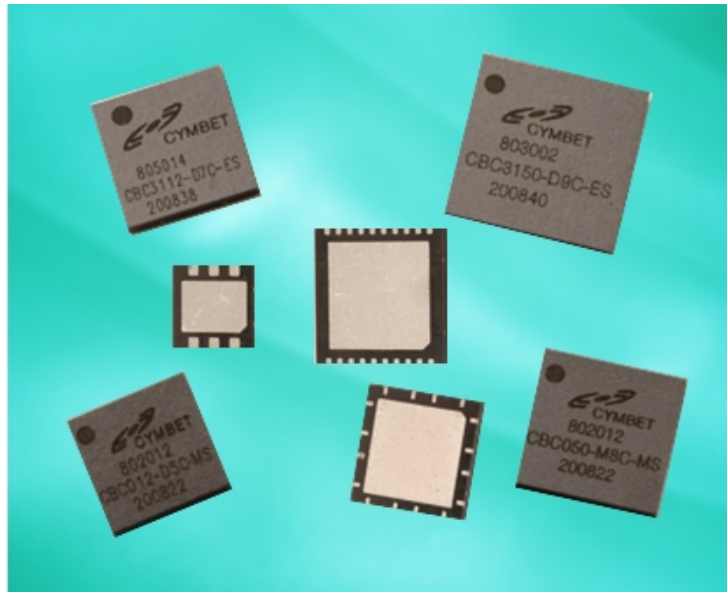

Figure 3: Examples of Solid State Thin-Film Batteries

Processor and Wireless Radio Link

The output of the sensor is typically connected to a microcontroller that processes the signal created from measuring the parameter of interest (e.g., temperature, pressure, acceleration, etc.) and converts it to a form that is useful for data transmission, collection, and analysis. Additionally, the microcontroller usually feeds this information to the radio and controls its activation at some prescribed time interval or based on the occurrence of a particular event. It is important that the microcontroller and radio are operating in low power modes whenever possible in order to maximize the power source lifetime. Depending on the quiescent current of the radio and microcontroller, the transmitter power and duty cycle, and the complexity and duration of any signal processing required, the drain on the power source can be dominated by steady state or active power consumption. Power consumption can also be reduced through microcontroller firmware algorithms that efficiently manage power up and power down sequences, analog-to-digital conversions, and event-driven interrupts.

Central Wireless Access Point

The Zero Power Wireless Sensors will communicate with a wireless access point/hub for receiving information from any number of remote wireless sensor nodes, aggregating the data, and connecting to the enterprise network. The access point – also referred to as the wireless host - is a centralized unit that communicates with, and collects information from, the remote nodes. It is generally connected directly to a computer, other monitoring system, or Local Area Network whereby the data is organized, stored for further analysis, and for providing real-time updates and response mechanisms.

A Zero Power Wireless Sensor Example

Combining the elements described earlier with Energy Harvesting yields a completely autonomous perpetual sensor. Figure 4 is a photo of a zero power wireless sensor demonstration kit. The discussion following Figure 3 focuses on the power module, microcontroller, and radio, referring to commercially available components as an example, with a view toward long life and maintenance-free operation in low power networks. In this example, we will describe the operation of the Solar Energy Harvesting EVAL-08 evaluation kit from Cymbet Corporation, in conjunction with the eZ430-RF2500 development platform from Texas Instruments.

Energy Harvesting Transducer Details

The Energy Harvesting Transducer block shown in Figure 1 suggests various types of transducer options. The easiest EH Transducer to demonstrate on a bench-top is a Photovoltaic (solar) cell. Cymbet supplies a Solar Energy Harvesting Demo Kit CBC-EVAL-08 that can be used as the transducer for an energy harvesting-based perpetual sensor. The EVAL-08 provides the solar cells and connections for the Power Module and the Processor and Radio Link board. The combo is shown in Figure 4.

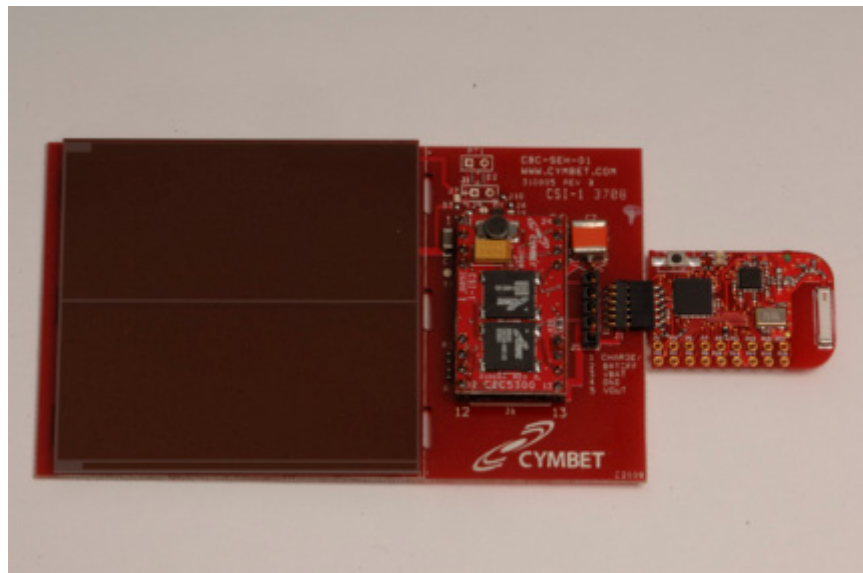

Figure 4: Cymbet EVAL-08 with TI Wireless Sensor

Power Module Details

The EnerChip EH CBC-5300 24-pin DIP power module located in the center of the EVAL-08 in Figure 4 consists of:

- 1) An energy harvesting optimized input circuit that receives power from any of the transducer types described above;
- 2) a DC-DC converter to step up the (usually) low input voltage;
- 3) an energy storage device;
- 4) load device power management;
- 5) and power module status I/O lines to communicate with the microcontroller.

The input circuit matches the impedance of the transducer, rectifies the voltage when necessary, and delivers the power to the DC-DC converter, whereby the voltage is stepped up and regulated at a level consistent with the required EnerChip charging voltage. This conversion is done efficiently as possible, so as not to waste much of the scarce input power available. Serving as the long-life energy storage device, the EnerChip provides power to the system during the periods when power to and from the transducer is not available. For example, in the case where the transducer is a photovoltaic cell and the sensor node is operating in a building where the lights are turned off nightly, the EnerChip would supply the power to the node overnight. During normal business hours, the power is supplied by the photovoltaic cell(s) and the EnerChip charge is replenished. In addition to providing reserve energy for the system, the EnerChip also functions as a voltage source to allow the power module input circuit to operate from a lower transducer output voltage than that required to start the system.

The power management section of the power module performs several useful functions, including handshaking features for communication with the microcontroller. A detection circuit determines whether enough power is available from the transducer to operate the system. If so, the microcontroller receives a signal indicating that the power module is operating normally. If insufficient power is available, a signal alerts the microcontroller to go into a low power mode and, if so programmed, send a signal to the wireless radio to alert the access point accordingly. There is also a control line that allows the user to disconnect the EnerChip from the circuit in order to use all available input power to operate the system, rather than diverting some of the power to the EnerChip to charge the cell.

Processor and Radio Link Example

As shown in Figure 4, the wireless end point is a Texas Instruments eZ430-RF2500 module using the MSP430 low power microcontroller and RF2500 radio. The eZ430-RF2500 is a complete wireless development tool for the MSP430 and CC2500 that includes all the hardware and software required to develop an entire wireless project with the MSP430 in a convenient USB stick. The tool includes a USB-powered emulator to program and debug applications in-system and two 2.4-GHz wireless target boards featuring the highly integrated MSP430F2274 ultra-low-power MCU. All the required software is included such as a complete Integrated Development Environment and SimpliciTI, a propriety low-power star wireless network stack,

enabling robust wireless networks out of the box. The eZ430-RF2500 uses the MSP430F22x4 which combines 16-MIPS performance with a 200-kcps 10-bit ADC and 2 op-amps and is paired with the CC2500 multi-channel RF transceiver designed for low-power wireless applications.

Energy Aware Wireless Protocols

SimpliciTI is a simple low-power RF network protocol aimed at small RF networks. Such networks typically contain battery operated devices which require long battery life, low data rate and low duty cycle (programmable) and have a limited number of nodes talking directly to each other or through an access point or range extenders. Access point and range extenders are not required but provide extra functionality such as store and forward messages. With SimpliciTI the MCU resource requirements are minimal which results in the low system cost. The SimpliciTI network protocol supports a wide range of low-power applications including alarm and security (smoke detectors, glass breakage detectors, carbon monoxide sensors, and light sensors), automated meter reading (gas meters and water meters), home automation (appliances, garage door openers, and environmental devices), and active RFID.

Conclusion

Wireless sensor systems are becoming more prevalent due to the rising installation costs of hard-wired sensor systems, availability of low cost sensor nodes, and advances in sensor technology. Energy Harvesting-based autonomous wireless sensor nodes are a cost-effective and convenient solution. The use of Energy Harvesting removes one of the key factors limiting the proliferation of wireless nodes - the scarcity of power sources having the characteristics necessary to deliver the energy and power to the sensor node for years without battery replacement. Significant economic advantages are realized when Zero Power Wireless Sensors are deployed vs. hard-wired solutions. Additional savings are realized by removing the significant costs of battery replacement. Combining Energy Harvesting transducers, an EnerChip-based energy harvesting Power Module, low power sensor, an energy aware Processor, and an optimized RF Radio link delivers the reality of long life, maintenance-free Zero Power Wireless Sensor Networks.