

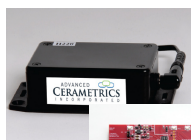

Demonstrating All Versions of Energy Harvesting

Cymbet is the leader in solid-state energy storage and energy harvesting solutions. EnerChip™ devices are the world's first component-class solid state energy storage device available in a surface-mount technology (SMT) package. It can be used like any SMT device with lead-free reflow tolerance and automated pick-and-place compatibility. The EnerChip CC and EnerChip EP devices enable various energy harvesting transducers to be used to power systems. With the environmentally friendly EnerChip, you get a reliable, low-profile, cost-effective device that provides power when you need it, where you want it. Cymbet has created a series of Energy Harvesting demonstrations using every type of transducer available. Videos of these demos can be seen at: <http://www.youtube.com/user/Cymbet>.



ENERCHIP EP ENERGY PROCESSOR AND EVAL-09 EH KIT

Vibration/Motion Energy Harvesting

The EnerChip EP Energy Processor is an integrated solution that provides energy storage and power management in systems requiring high efficiency energy conversion and optimal energy storage. The EnerChip EP can perform Maximum Peak Power Tracking energy harvesting for the **Advanced Cerametrics Harvester™ III** and **Mide Volture™** Piezoelectric-based vibration energy harvesting modules.

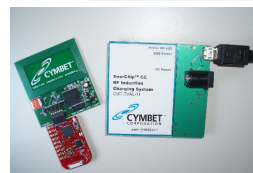

ENERCHIP CC CBC3150 AND EVAL-11 KIT

RF Induction Charging - Near Field

The EnerChip CC can also be charged using an RF field applied at close range (less than 0.5 inches). The EVAL-11 RF Induction Eval Kit has an interface for the **Texas Instruments eZ430-RF2500** wireless end device. This configuration demonstrates an autonomous wireless sensor node or data logging system. Potential applications include real time location monitoring, cold chain status data storage, and medical sensors for patient monitoring.

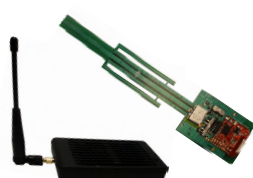

ENERCHIP CC CBC3150

RF Induction Charging - Far Field

The EnerChip CC CBC3150 can serve as the energy storage and power management device for the **PowerCast PowerCaster™** wireless power transmission modules. The EnerChip CC provides the backup power for the **PowerHarvester™** receiver when the RF signal is not present. It provides supplemental power when the RF signal is weak. This is a very cost effective way to create autonomous wireless sensors for Intelligent Building management.

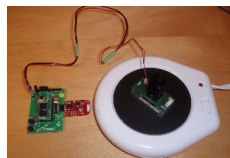

ENERCHIP EP AND EVAL-09 UNIVERSAL EH KIT

Thermal Energy Harvesting

A **Micropelt TE-Power Plus™** or **Nextreme AV-series thermal electric generator™** is connected to an EVAL-09 Universal EH Eval Kit to create an autonomous wireless sensor harvesting energy from thermal gradients. This demo shows how wireless sensors using the TI eZ430-RF2500 wireless kit could be powered from machinery, hot/cold fluid pipes, or any surface with a thermal gradient.

EVAL-08 SOLAR EH KIT, EVAL-09 EP KIT AND EVAL-10 ENERCHIP CC EH KIT

Solar Energy Harvesting

Two Solar Energy Harvesting demos are shown here. A **Konarka PowerPlastic™** flexible solar cell mounted on a cylinder and connected to the Cymbet EVAL-10 EnerChip CC EH kit to create an autonomous wireless sensor. Also shown is the Texas Instruments eZ430-RF2500-SEH which is a turnkey solar wireless demo Kit. The EVAL-08 also works with the **Microchip XLP Demo Kit**. The TI eZ430-RF2500-SEH and Microchip XLP kits are currently available from **Avnet**, **Digi-Key** or **Mouser** on their websites.

ENERCHIP EP AND EVAL-09 KIT

Flow Energy Harvesting Using Electromagnetic Conversion

This demo shows how flow of any kind - wind, airflow in ducts, water, process fluids, etc. can be converted to energy using turbines or other flow conversion energy transducers. The resulting harvested electricity powers a Cymbet EnerChip EP EVAL-09 Kit that drives the **TI eZ430-RF2500** wireless end device. Autonomous wireless sensor networks can be powered completely from the "free" energy flowing in pipes, ducts or the atmosphere.



EnerChips: Compare to SuperCaps and Coin Cells

Feature	EnerChip CC	SuperCap	Coin Cell
High-cycle life (>5000)	✓	✓	X
No external charge circuit	✓	✓	X
No sockets/holders	✓	✓	X
SMT Assembly	✓	-	-
Low self discharge	✓	X	✓
Stable output voltage	✓	X	✓
Smaller area	✓	X	X
No hazardous chemicals	✓	X	X
Internal Supply Supervisor	✓	X	X
Power Fail Indicator	✓	X	X
Integrated DC-DC Converter	✓	X	X

EnerChip Applications

- **Standby supply** for non-volatile SRAM, Real-time clocks, controllers, supply supervisors, and other system-critical components.
- **Wireless sensors and RFID tags** and other powered, low duty cycle applications.
- **Localized power source** to keep microcontrollers and other devices alert in standby mode.
- **Power bridging** to provide back-up power to system during exchange of primary batteries.
- **Medical devices** can utilize EnerChip permanent power features for monitoring and wearables.
- **SmartCard Power** applications can leverage the small size of the EnerChip.
- **Energy Harvesting** is enabled by the thousands of charge cycles available on the EnerChip.

EnerChip™ CC CBC3150 Block Diagram

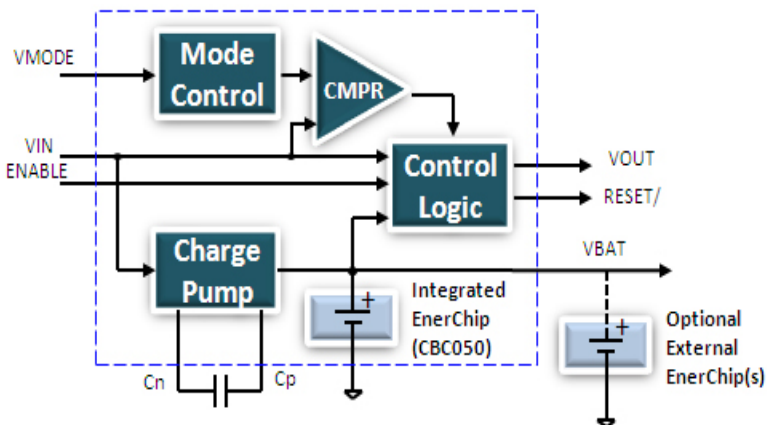

Cymbet Distribution Partners



Cymbet Product Solutions

Product	Description
	CBC012 – EnerChip 12uAh Rechargeable Solid State Battery - 6 pin DFN
	CBC050 – EnerChip 50uAh Rechargeable Solid State Battery - 16 pin QFN
	CBC3112 – EnerChip CC 12uAh Rechargeable Solid State Battery with Integrated Power Management -20 pin DFN
	CBC3150 – EnerChip CC 50uAh Rechargeable Solid State Battery with Integrated Power Management –20 pin DFN
	EnerChip Bare Die – 1uAh, 5uAh, 12uAh, 50uAh. Wire bond or bumped attach.
	CBC915 EnerChip Energy Processor with Maximum Peak Power Tracking
	CBC5300 - EnerChip EH Energy Harvesting Module
	CBC-EVAL-05 EnerChip Evaluation Kit with CBC3112 and CBC3150
	CBC-EVAL-08 EnerChip Solar Energy Harvesting Evaluation Kit
	CBC-EVAL-09 EnerChip Energy Processor Universal Energy Harvesting Kit
	CBC-EVAL-10 EnerChip CC Solar Energy Harvesting Evaluation Kit
	CBC-EVAL-11 EnerChip CC RF Induction Charging Evaluation Kit

Cymbet Strategic Investors



TEXAS INSTRUMENTS



Industry Awards and Recognition



Editor's CHOICE

Eco-Friendly Environmental Compliance

